

Corrosion-proof and resistant to acid and salt

Grease nipples ensure a long lifetime for all moving components

Electric lift (AMX I10e)

Smooth surface for easy cleaning

Robust and long-lasting



AMX I10/I10p **AMX I10e/I10ep**

Stainless steel scissor lift hand pallet truck (1000 kg)

The stainless steel versions of the AMX 10/AMX 10e scissor lift hand pallet trucks are ideal for transporting goods in areas where absolute hygiene is required. The advantages of the stainless steel range come to the fore in damp and hostile environments.

Individually adaptable to the application at hand, you can choose from a range of versions. Jungheinrich's decades of experience in stainless steel hand pallet trucks is reflected today in its completely reliable and robust trucks.

In meat or fish processing, chemical or pharmaceuticals sectors, the scissor lift trucks offer the right solution.

AMX I10/I10p and AMX I10e/I10ep

AMX I10/I10p

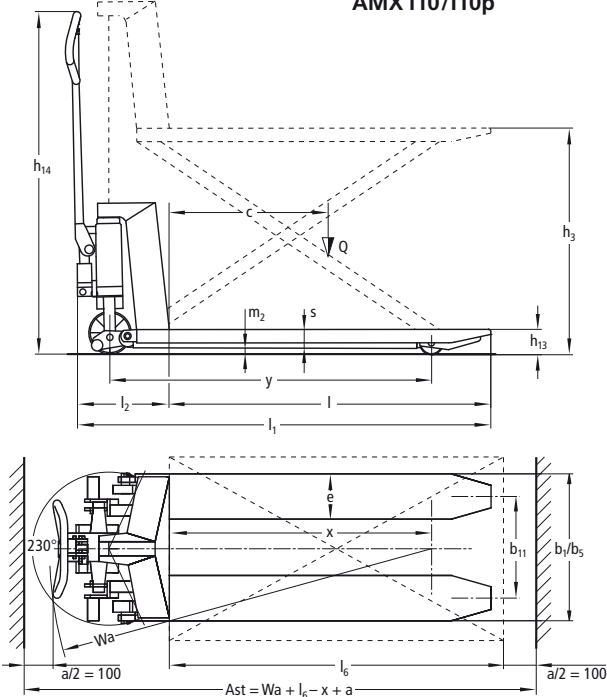

AMX I10e/I10ep

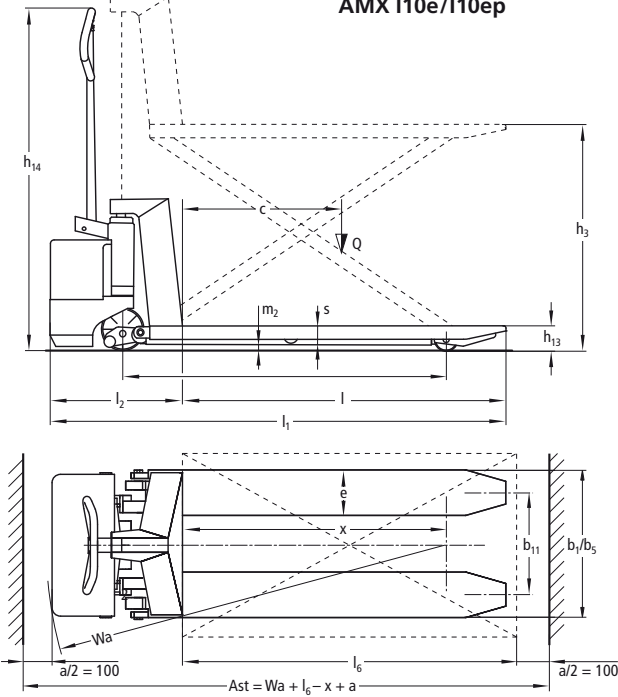

Technical Data in line with VDI 2198 as at: 09/2011

Identification	1.1	Manufacturer (abbreviation)		Jungheinrich	Jungheinrich	1.1
	1.2	Manufacturer's type designation		AMX 110/I10p	AMX 110e/I10ep	1.2
	1.3	Drive		manual	electric (lift)	1.3
	1.4	Type of operation		pedestrian	pedestrian	1.4
	1.5	Load capacity/rated load	Q (t)	1	1	1.5
	1.6	Load centre distance	c (mm)	600	600	1.6
	1.8	Load distance, centre of drive axle to fork	x (mm)	925	925	1.8
	1.9	Wheelbase	y (mm)	1140	1140	1.9
	Weights	2.1	Service weight incl. battery (see line 6.5)	kg	108	140
2.2		Axle loading, laden front/rear	kg	358/750	367/753	2.2
2.3		Axle loading, unladen front/rear	kg	70/38	85/35	2.3
Wheels, Chassis	3.1	Tyres		N; V	N; V	3.1
	3.2	Tyre size, front	mm	Ø 150x42; Ø 150x40	Ø 150x42; Ø 150x40	3.2
	3.3	Tyre size, rear	mm	80	80	3.3
	3.5	Wheels, number front/rear (x = driven wheels)		2/2 or 2/4	2/2 or 2/4	3.5
	3.6	Track width, front	b ₁₀ (mm)	145	145	3.6
	3.7	Track width, rear	b ₁₁ (mm)	440	440	3.7
	Basic Dimensions	4.4	Lift height	h ₃ (mm)	800	800
4.9		Height of tiller in drive position min. /max.	h ₁₄ (mm)	1195	1195	4.9
4.14		Standing height, elevated	h ₁₂ (mm)	800	800	4.14
4.15		Lowered height	h ₁₃ (mm)	90	90	4.15
4.19		Overall length	l ₁ (mm)	1480	1580	4.19
4.20		Length to face of forks	l ₂ (mm)	340	440	4.20
4.21		Overall width	b ₁ /b ₂ (mm)	540/680	540/680	4.21
4.22		Fork dimensions	s/e/l (mm)	50/163/1140	50/163/1140	4.22
4.25		Width over forks	b ₅ (mm)	540	540	4.25
4.32		Ground clearance, centre of wheelbase	m ₂ (mm)	28	28	4.32
4.34		Aisle width for pallets 800x1200 lengthways	Ast (mm)	1830	1890	4.34
4.35		Turning radius	Wa (mm)	1355	1415	4.35
Performance Data		5.3	Lowering speed, laden/unladen	m/s	0.15/0.09	0.08/0.05
Electric Engine	6.2	Lift motor rating at S ₃ 10 %	kW	-	1.1	6.2
	6.4	Battery voltage, nominal capacity K _s	V/Ah	-	12/60	6.4
	6.5	Battery dimensions	kg	-	20	6.5

Make use of the advantages

Easy to handle

- Smooth control for left and right handed operation.
- Special lowering valve for sensitive, controlled load lowering.
- Short overall length (340 mm) for safe operation in restricted conditions.
- Brackets on the fork tips allow for easy pallet handling.



AMX I10 control



AMX I10e control

Hygiene to the nth degree

- The enclosed fork tips ensure that no dirt sprays up from the fork rollers onto the load during travel.
- Freely accessible or fully enclosed cavities allow for effective cleaning without leaving any bacteria "hiding spots".
- Grease nipples on moving parts.
- Food grade lubricant (class H1 and H2).



Enclosed fork tips

Lift height

Extra standing legs offer good stability up to a height of 800 mm.

Easy lifting and lowering

- Option of manual hydraulic (AMX I10) or electro-hydraulic (AMX I10e) with 1.1 kW lift motor.
- Integrated pump unit and reservoir.
- Sensitive lowering through hand lever. The lowering valve is incorporated in the pump unit. The hydraulic system is protected from overload by a pressure relief valve.

Forks

Robust, torsion-resistant design with enclosed fork tips.

Maintenance-free battery and on-board charger (AMX I10e)

- On-board battery charger.
- Re-charge at any 13 A socket.
- Maintenance-free 60 Ah battery.

Material comparison	AMX I10/I10e								AMX I10p/I10ep							
	Chassis	Tiller	Axle	Support arm lever	Sideways/reversing lever	Scissor lift legs	Pump	Pump unit cover ¹⁾	Chassis	Tiller	Axle	Support arm lever	Sideways/reversing lever	Scissor lift legs	Pump	Pump unit cover ¹⁾
Acid-resistant steel (AISI 316)	•								•							
Stainless steel (AISI 303/304)		•	•	•						•	•	•	•	•	• ²⁾	•
Metal jacket coating					•	•		•								
Chrome finish							•								• ³⁾	

1) E version 2) AMX I10ep 3) AMX I10p

Jungheinrich UK Ltd.

Head Office:

Sherbourne House · Sherbourne Drive

Tilbrook · Milton Keynes MK7 8HX

Phone 01908 363100

Fax 01908 363180

info@jungheinrich.co.uk

www.jungheinrich.co.uk



Jungheinrich trucks conform to the European Safety Requirements.



JUNGHEINRICH
Machines. Ideas. Solutions.