

3000 kg capacity

Reinforced frame

Fast lift supplied as standard

Unique operating element

Robust and durable

Short and manoeuvrable



AM 30

Hand pallet truck (3000 kg)

The hand pallet trucks AM 30 is the ideal solution for all manual transport tasks over short distances. It is a universally suitable truck with its extraordinarily high capacity – for very heavy loads as well as for loads that exceed the usual dimensions. Its advantages are detailed here:

- Comfortable and easy to handle operating element for both left-handed and

right-handed operators. Manoeuvring with one hand on the tiller head is possible and both comfortable and safe.

- Fast lift (up to 120 kg) with supplied as standard for off the floor lifting and lowering of pallets in only three pump strokes.
- Excellent manoeuvrability even in most confined spaces through slim front length.

Chromed bearing bushes on wheels and joints make for easy pulling or pushing. They are convincing with their remarkably quiet running and maintenance free operation.

AM 30

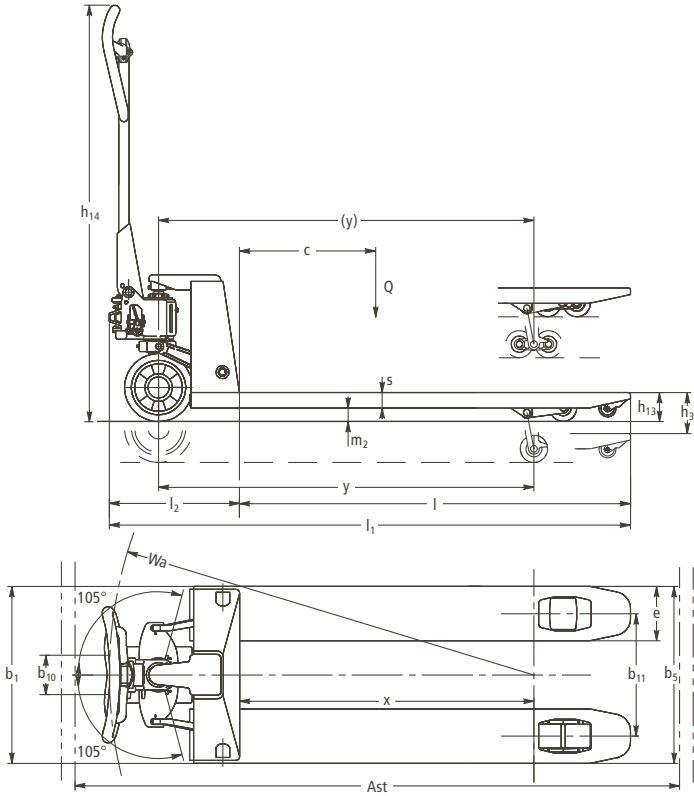

Technical Data in line with VDI 2198 as at: 02/2009

Identification	1.1	Manufacturer (abbreviation)	Jungheinrich	Jungheinrich	1.1
	1.2	Manufacturer's type designation	AM 30	AM 30	1.2
	1.3	Drive: electric (battery or mains), diesel, petrol, fuel gas, manual	manual	manual	1.3
	1.4	Type of operation: hand, pedestrian, standing, seated, order picker	hand	hand	1.4
	1.5	Load capacity/rated load Q (t)	3	3	1.5
	1.6	Load centre distance c (mm)	600	1050	1.6
	1.8	Load distance, centre of drive axle to fork x (mm)	936	1801	1.8
	1.9	Wheelbase y (mm)	1174	2054	1.9
	Weights	2.1	Service weight kg	86	142
2.2		Axle loading, laden front/rear kg	815/2270	1135/2007	2.2
2.3		Axle loading, unladen front/rear kg	27.5/57.5	57/85	2.3
Wheels, Chassis	3.1	Tyres: solid rubber, superelastic, pneumatic, polyurethane	V	V	3.1
	3.2	Tyre size, front	200	200	3.2
	3.3	Tyre size, rear	80x70	80x70	3.3
	3.5	Wheels, number front/rear (x = driven wheels)	2/4	2/4	3.5
	3.6	Track width, front b ₁₀ (mm)	116	116	3.6
	3.7	Track width, rear b ₁₁ (mm)	390	390	3.7
	Basic Dimensions	4.4	Lift height h ₃ (mm)	120	120
4.9		Height of tiller in drive position min./max. h ₁₄ (mm)	1224	1224	4.9
4.14		Standing height, elevated h ₁₂ (mm)	205	205	4.14
4.15		Lowered height h ₁₃ (mm)	85	85	4.15
4.19		Overall length l ₁ (mm)	1603	2483	4.19
4.20		Length to face of forks l ₂ (mm)	383	383	4.20
4.21		Overall width b ₁ /b ₂ (mm)	550	550	4.21
4.22		Fork dimensions s/e/l (mm)	45x160x1220	63x160x2100	4.22
4.25		Width over forks b ₅ (mm)	550	550	4.25
4.32		Ground clearance, centre of wheelbase m ₂ (mm)	36	18	4.32
4.33		Aisle width for pallets 1000x1200 crossways Ast (mm)	1803	2683	4.33
4.34		Aisle width for pallets 800x1200 lengthways Ast (mm)	1803	2683	4.34
4.35		Turning radius Wa (mm)	1319	2184	4.35
Performance Data	5.3	Lowering speed, laden/unladen m/s	0.09/0.05	0.09/0.05	5.3

Make use of the advantages

Effortless transport of heavy loads

- The special reinforcements of load-carrying parts makes the AM 30 ideally suitable for the transport of particularly heavy loads

Designs for every application

- Varying fork lengths ensure that even loads with extreme centres of gravity can be transported safely.

Easy to handle

- The smooth running operating element is equally suitable for left-handed and right-handed operators.
- The special lowering valve facilitates loads to be lowered particularly sensitively and proportionally.
- The standard fast lift (up to 120 kg) ensures that Euro pallets are lifted off the floor with only three pump strokes. Maximum lift height is achieved in only 5 pump strokes.



Robust forks



Operating element

Excellent manoeuvrability

- 105° to all sides ensures maximum manoeuvrability, even in narrow aisles or on a lorry.

Jungheinrich UK Ltd.

Head Office:

Sherbourne House · Sherbourne Drive
Tilbrook · Milton Keynes MK7 8HX
Phone 01908 363100
Fax 01908 363180

info@jungheinrich.co.uk
www.jungheinrich.co.uk

Jungheinrich AG
ISO 9001, ISO 14001
Certification of Quality and
Environment Management.



Jungheinrich trucks
conform to the European
Safety Requirements.



JUNGHEINRICH
Well worthwhile